

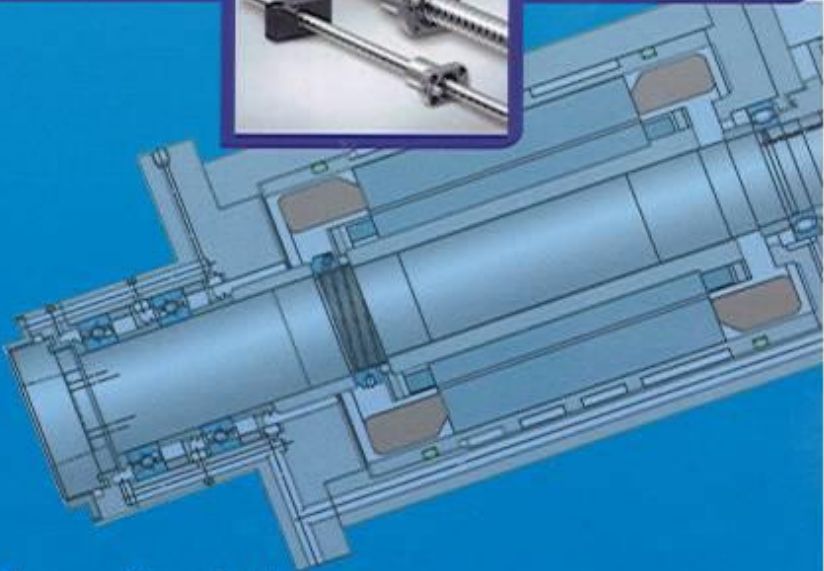

**PMK Spindle & Ball Screw
Repair / Maintenance Program**



The Spindle & Ball Screw Specialists

PMK Spindle & Ball Screw Repair / Maintenance Program

A COMPREHENSIVE RANGE
OF INTEGRATED

SPINDLE & BALL SCREW MAINTENANCE & REPAIR SERVICES

SERVING INDUSTRIAL &
AUTOMOTIVE CUSTOMERS

FAST REPAIR OF INTEGRATED (MOTORISED) AND MECHANICAL SPINDLES FOR MACHINE TOOLS AND SPECIFIC CNC MACHINING CENTERS

A spindle is among the most critical and expensive components of a complex machine tool. And maintaining a large park of spindles is time-consuming and costly. Although it is often more economical to rebuild a spindle than to replace it, this requires

special equipment and skilled technicians. Machine tool users can benefit from our comprehensive spindle service program: it ranges from repair; to reconditioning, to redesign. It covers all spindle brands and types.

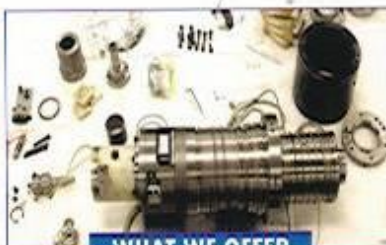

WHAT WE OFFER

Single-source service for all spindle brands, types & sizes

Field consultancy

Repair & reconditioning

Spindle system redesign & enhancement

Full maintenance contracts

Skill and industry experience

Global engineering support network.



WHAT YOU GET

Integrated services & tailored solutions

Latest technology & highest quality components

Flexible response times & experienced technicians

Reduced operating costs & superior performance

Easy handling of requests & quotations



REBUILD/UPGRADE OF ANY SPINDLE/ANY BRAND/AND ANY SIZE

THREE LEVELS OF SERVICE

REPAIR & RECONDITIONING



- ✦ Inspect spindle and system components
- ✦ Rework/replace damaged components
- ✦ Replace precision bearing (with the brand of your choice)
- ✦ Rebuild bearing housing
- ✦ Electrical checks and shaft balancing
- ✦ Complete run-in and bench testing to simulate field parameters under controlled conditions

ADVANCE REBUILD



- ✦ All repair and reconditioning activities listed above
- ✦ Assess detailed failure mode analysis
- ✦ Modify standard bearing design to extend service life
- ✦ Optimize design to permit either higher turning speeds or improved shaft stiffness
- ✦ Recondition tapers and repair live tools
- ✦ Rewind electric motors
- ✦ Manage spare parts

ENGINEERED UPGRADE

Based on broad engineering experience in spindle design and components enhancement, there are a range of solutions to extend life and increase productivity.



- ✦ Conversion from journal to rolling element bearings
- ✦ Upgrade seals
- ✦ Mechanical modifications, such as ends of shaft and clamping systems
- ✦ Improvements to increase power/speed and help the spindle meet production needs

Benefits for the Customer

- Reduce Costs
- Raise Productivity
- Extend Machine Tool Life

- All spindle types
- All bearing types and brands
- 12-month warranty
- Engineering expertise, evaluation and consulting

- The right level of service to meet your needs
- Preventive maintenance contracts
- Customized training programs
- Repair and manufacturing of parts and mechanical components
- Grinding up to 2000mm OD and 1950mm ID; max length 3000mm.
- Dynamic shaft balancing up to 150 Kg

We can repair your ball screw in 12 to 24 hours!

Lots of companies offer "Changing of Balls" of a screw, which is fine if you want it to last a few months. If you want it to last a few years then you need to do a complete rebuild the Ball Screw with us.



1. Check the load of the nut at each end of the screw & in the center locating any trouble spots
2. Complete disassembly of the ball screw and nut, checking ball size, ball groove depth, returns, etc.
3. Thread grinding (ball grooves) your screw end to end.
4. ID grind the nut (ball grooves) to the same size & tolerance as the screw & replace all tubes, returns
5. Precision grind & polish a new set of balls to match the newly ground ball grooves on your screw/nut
6. Final assembly to original preload, replacing all wipers & seals, inspection, testing & packaging.
7. If bearing seatings are damaged, we can OD grind and chrome plate back to OEM specs.

The end result is a completely remanufactured ball screw that will last years instead of months. We offer a 12 month warranty because we completely remanufacture your ball screw.

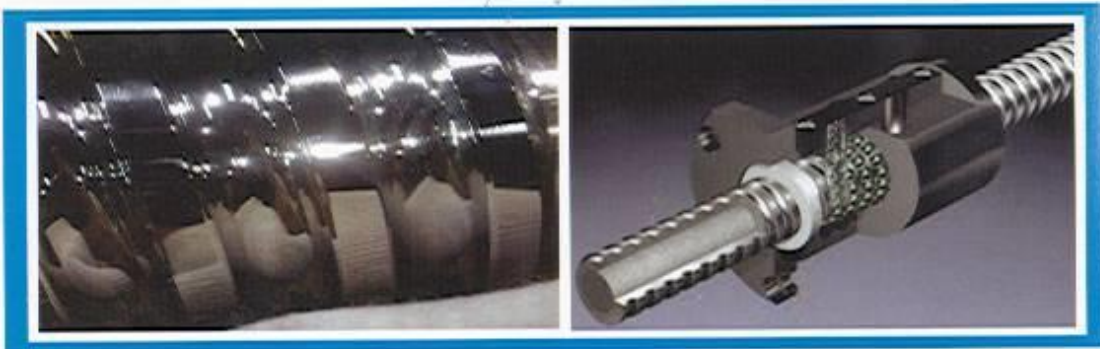

PRECISION MACHINEKRAFT (P) LTD

Bangalore

#11/2, Lakshmi pura Road,
Abbigere Indl Area, Bangalore - 560 090
Tel : 080-65376667 / 8, 32945451,
Fax : 080-2325148
E-mail : support@pmkindia.com

Pune

Plot No. 168, Sector 10
PCNTDA, Bhosari, Pune 411026
Tel : +91-9422035516
Fax : 020-65008274
E-mail : pande@pmkindia.com

Kolkata

#11, Clive Row,
Kolkata 700001
Tel : 033-22425326 / 8726
Fax : 033-22432786
E-mail : atg@bscindia.com

[www. pmkindia.com](http://www.pmkindia.com)

PMK and Customer compliance on technical issues related to Comprehensive Spindle / Rotary Table / Ball Screws Rebuild Program.

SI No	Subject	Compliance
1	Using original spares, as and when required	Yes will be provided
2	Changing OTT drawbar, if required	Yes we will take details of the draw bar and shall keep an inventory of the same
3	Changing seals, cups, o-rings, if required	Yes , the same will be done and stock maintained.
4	Changing bearings, if required	Yes , we normally carry a good inventory of High Speed Ceramic Bearings
5	Tool clamping position setting	Yes can be provided
6	Changing of rotary union, if required	Yes can be provided
7	Changing of all electronic sensors and components, if required	Yes can be provided
8	Changing of all electrical connectors, if required, and it should match the machine side connectors, and has seals for protection against contamination ingress.	Yes can be provided
9	Rewinding, if required	Yes rewinding can be done
10	Any extra work, which will be jointly decided and agreed upon.	Agreed and complied with
11	Warranty period of 1yr	Agreed and complied with
12	Sharing of Engineering data (assembly drawings, spec of parts with part nos, spare inventory data, engineering calculations etc.)	Will be done provided point no.15 is complied with
13	Agreement on Technology Transfer of spindle reconditioning (ToT)	Will be done provided point no.15 is complied with
14	Helping with the know-how to build our own Test Rig to test refurbished spindle in-house	Will be done provided point no.15 is complied with
15	Non-Disclosure Agreement, if required	A NDA is to be signed by Customer (authorized signatory) confirming that whatever technology , design or training or details that are passed on by PMK to Customer , will be kept confidential and shall not be utilized for any other purpose other than maintenance and upkeep of Spindles at Customers end.



**PMK Spindle & Ball Screw
Repair / Maintenance Program**

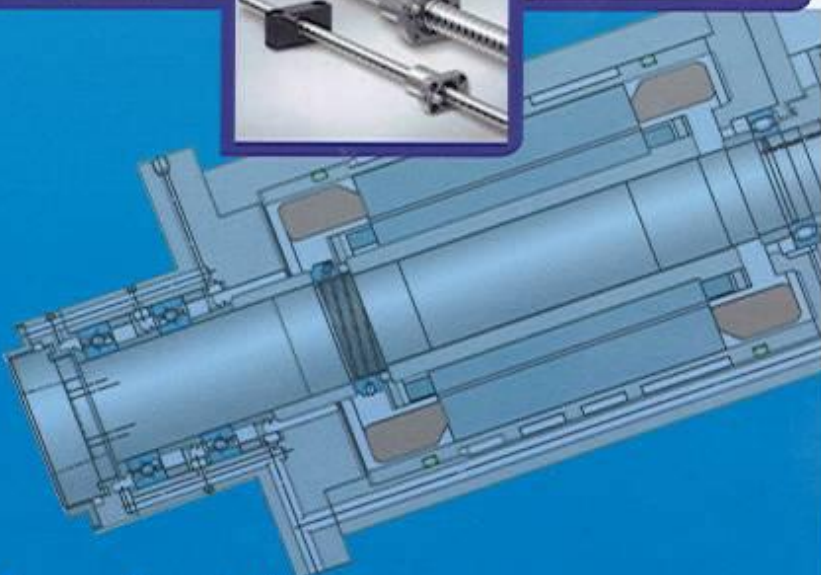

The Spindle & Ball Screw Specialists

PMK Spindle & Ball Screw Repair / Maintenance Program

A COMPREHENSIVE RANGE
OF INTEGRATED

SPINDLE & BALL SCREW MAINTENANCE & REPAIR SERVICES

SERVING INDUSTRIAL &
AUTOMOTIVE CUSTOMERS

FAST REPAIR OF INTEGRATED (MOTORISED) AND MECHANICAL SPINDLES FOR MACHINE TOOLS AND SPECIFIC CNC MACHINING CENTERS

A spindle is among the most critical and expensive components of a complex machine tool. And maintaining a large park of spindles is time-consuming and costly. Although it is often more economical to rebuild a spindle than to replace it, this requires

special equipment and skilled technicians. Machine tool users can benefit from our comprehensive spindle service program: it ranges from repair; to reconditioning, to redesign. It covers all spindle brands and types.



WHAT WE OFFER

Single-source service for all spindle brands, types & sizes

Field consultancy

Repair & reconditioning

Spindle system redesign & enhancement

Full maintenance contracts

Skill and industry experience

Global engineering support network.

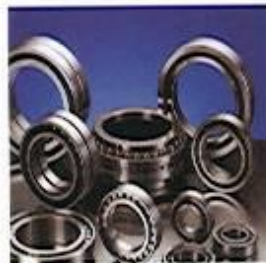

WHAT YOU GET

Integrated services & tailored solutions

Latest technology & highest quality components

Flexible response times & experienced technicians

Reduced operating costs & superior performance

Easy handling of requests & quotations



REBUILD/UPGRADE OF ANY SPINDLE/ANY BRAND/AND ANY SIZE

THREE LEVELS OF SERVICE

REPAIR & RECONDITIONING



- ✦ Inspect spindle and system components
- ✦ Rework/replace damaged components
- ✦ Replace precision bearing (with the brand of your choice)
- ✦ Rebuild bearing housing
- ✦ Electrical checks and shaft balancing
- ✦ Complete run-in and bench testing to simulate field parameters under controlled conditions

ADVANCE REBUILD



- ✦ All repair and reconditioning activities listed above
- ✦ Assess detailed failure mode analysis
- ✦ Modify standard bearing design to extend service life
- ✦ Optimize design to permit either higher turning speeds or improved shaft stiffness
- ✦ Recondition tapers and repair live tools
- ✦ Rewind electric motors
- ✦ Manage spare parts

ENGINEERED UPGRADE

Based on broad engineering experience in spindle design and components enhancement, there are a range of solutions to extend life and increase productivity.



- ✦ Conversion from journal to rolling element bearings
- ✦ Upgrade seals
- ✦ Mechanical modifications, such as ends of shaft and clamping systems
- ✦ Improvements to increase power/speed and help the spindle meet production needs

Benefits for the Customer

- Reduce Costs
- Raise Productivity
- Extend Machine Tool Life

- All spindle types
- All bearing types and brands
- 12-month warranty
- Engineering expertise, evaluation and consulting

- The right level of service to meet your needs
- Preventive maintenance contracts
- Customized training programs
- Repair and manufacturing of parts and mechanical components
- Grinding up to 2000mm OD and 1950mm ID; max length 3000mm.
- Dynamic shaft balancing up to 150 Kg

We can repair your ball screw in 12 to 24 hours!

Lots of companies offer "Changing of Balls" of a screw, which is fine if you want it to last a few months. If you want it to last a few years then you need to do a complete rebuild the Ball Screw with us.



1. Check the load of the nut at each end of the screw & in the center locating any trouble spots
2. Complete disassembly of the ball screw and nut, checking ball size, ball groove depth, returns, etc.
3. Thread grinding (ball grooves) your screw end to end.
4. ID grind the nut (ball grooves) to the same size & tolerance as the screw & replace all tubes, returns
5. Precision grind & polish a new set of balls to match the newly ground ball grooves on your screw/nut
6. Final assembly to original preload, replacing all wipers & seals, inspection, testing & packaging.
7. If bearing seatings are damaged, we can OD grind and chrome plate back to OEM specs.

The end result is a completely remanufactured ball screw that will last years instead of months. We offer a 12 month warranty because we completely remanufacture your ball screw.



PRECISION MACHINEKRAFT (P) LTD

Bangalore

#11/2, Lakshmi pura Road,
Abbigere Indl Area, Bangalore - 560 090
Tel : 080-65376667 / 8, 32945451,
Fax : 080-2325148
E-mail : support@pmkindia.com

Pune

Plot No. 168, Sector 10
PCNTDA, Bhosari, Pune 411026
Tel : +91-9422035516
Fax : 020-65008274
E-mail : pande@pmkindia.com

Kolkata

#11, Clive Row,
Kolkata 700001
Tel : 033-22425326 / 8726
Fax : 033-22432786
E-mail : atg@bscindia.com

[www. pmkindia.com](http://www.pmkindia.com)

PMK and Customer compliance on technical issues related to Comprehensive Spindle / Rotary Table / Ball Screws Rebuild Program.

SI No	Subject	Compliance
1	Using original spares, as and when required	Yes will be provided
2	Changing OTT drawbar, if required	Yes we will take details of the draw bar and shall keep an inventory of the same
3	Changing seals, cups, o-rings, if required	Yes , the same will be done and stock maintained.
4	Changing bearings, if required	Yes , we normally carry a good inventory of High Speed Ceramic Bearings
5	Tool clamping position setting	Yes can be provided
6	Changing of rotary union, if required	Yes can be provided
7	Changing of all electronic sensors and components, if required	Yes can be provided
8	Changing of all electrical connectors, if required, and it should match the machine side connectors, and has seals for protection against contamination ingress.	Yes can be provided
9	Rewinding, if required	Yes rewinding can be done
10	Any extra work, which will be jointly decided and agreed upon.	Agreed and complied with
11	Warranty period of 1yr	Agreed and complied with
12	Sharing of Engineering data (assembly drawings, spec of parts with part nos, spare inventory data, engineering calculations etc.)	Will be done provided point no.15 is complied with
13	Agreement on Technology Transfer of spindle reconditioning (ToT)	Will be done provided point no.15 is complied with
14	Helping with the know-how to build our own Test Rig to test refurbished spindle in-house	Will be done provided point no.15 is complied with
15	Non-Disclosure Agreement, if required	A NDA is to be signed by Customer (authorized signatory) confirming that whatever technology , design or training or details that are passed on by PMK to Customer , will be kept confidential and shall not be utilized for any other purpose other than maintenance and upkeep of Spindles at Customers end.

CASE STUDY: CORREA ANAYAK BT50 SPINDLE HEAD REPAIR

PMK (Precision Machinekraft Pvt Ltd) is an unique organisation and are specialists in DESIGNING, MANUFACTURING AND TESTING of :

Cartridge Spindles (Belt Driven, Gear Driven and Integrated-Motor Driven) .

PMK is proud to present a case study on a REBUILD of **CORREA ANAYAK BT50 SPINDLE HEAD**

Spindle MAX RPM : 2200

Customer Reported Problem :

- Spindle Noise & More vibration
- Run out on mandrel up to 0.1mm @350mm length

Interesting special work In CORREA ANAYAK BT50 SPINDLE HEAD REPAIR
We have succefully replaced precision class sealed bearings as well as eliminated gear backlash

Final Inspection Results

- Spindle run out checked on taper nose is less than 0.002mm
- Spindle run out on mandrel @350mm length is less than 0.015mm
- Spindle taper nose blue match is above 90%
- Checked for vibration which should be less than 0.1mm/sec
- Spindle run and Stabilised upto 2200RPM (Temp= 26 °C)

Advanatages To Customer

- 1 Year warranty on spindle repair
- Repairing Time 5-6days
- Very optimum repairing cost



Company Address : Plot No - 168, Sector -10 , PCNDTA , Bhosari-Pune -26

MB : 7666608886 / 9591994067

www.pmkindia.com

CASE STUDY : HYDRODYNAMIC SPINDLE REPAIR

PMK (Precision Machinekraft Pvt Ltd) is an unique organisation and are specialists in DESIGNING, MANUFACTURING AND TESTING of :

Cartridge Spindles (Belt Driven, Gear Driven and Integrated-Motor Driven) . We have produced spindle upto 100Kw and 100000 rpm.

PMK is proud to present a case study on a REBUILD of Hydrodynamic Spindle of PMT , (PMK possesses the technology to design , manufacture and Rebuild of Hydrostatic/Hydrodynamic and Aerostatic Spindles). We have carried out these rebuilds also for TOSS/ MICROMATIC/ROBBIE/CINCINNATI/HEALD grinding machines.

Spindle Max RPM - 1400

Customer Reported Problem

- * Spindle Noise
- * Spindle Taper Blue match
- * Spindle vibration more

Interesting Special Work in Hydrodynamic Spindle Repair activity

We have successfully replace bush bearings as well as ceramic coating apply on spindle shaft

Final Inspection Results

- * Spindle run out checked on taper nose is less than 0.002mm
- * Spindle taper nose blue match is above 90%
- * Checked for vibration which should be less than 0.1mm/sec
- * Spindle run and stabilize up to 1400RPM (Temp-25 °C)

Advantages to customers

- * 1 Year Warranty on Spindle Repair
- * Repairing Time 5-9 days
- * Very optimum repairing cost



Sector- 10,Plot No-108 , PCMDTA,Bhosari ,Pune - 20